

2100SJ

TELESCOPING MEGA BOOM LIFT



- 5 steering modes, including lateral drive for exceptional maneuverability
- Industry-leading outreach
- Secondary platform controls for precise positioning
- Patent pending design

 **snorkel**[™]
www.snorkellifts.com

TELESCOPING MEGA BOOM LIFT

2100SJ

DIMENSIONS	TB120	TB126J
Max. Working Height (A)		216' (65.83m)
Max. Platform Height		210' (64.00m)
Max. Horizontal Reach		115' (35.05m)
Platform Size	8' x 3' (2.44m x 0.91m)	
Overall Length (B)		72' (21.94m)
Overall Width (C)		8' 2" (2.49m)
Operational Width (Axles extended)		18' (5.48m)
Stowed Height (D)		10' (3.05m)
Transport Length		51' (15.54m)
Ground Clearance		14" (355mm)

PERFORMANCE	
Platform Capacity (Restricted)	1,000 lbs (454kg)
Platform Capacity (Unrestricted)	770 lbs (349kg)
Max. Drive Height	210' (26.21m)
Max. Wind Speed	28mph (12.5m/s)
Max. Drive Speed (Stowed)	2.5mph (4.0km/h)
Max. Drive Speed (Elevated)	0.15mph (0.24km/h)
Gradeability	35%
Jib Length	6' 6" (1.98m)
Jib Arc	128° (+73°/-55°)
Platform Rotation	150°
Superstructure Rotation	360° continuous
Tailswing (Axles Retracted)	80.7" (2.05m)
Tailswing (Axles Extended)	54.25" (1.38m)
Inside Turning Radius (Axles Retracted)	10' (3.04m)
Inside Turning Radius (Axles Extended)	8' 6" (2.59m)
Outside Turning Radius (Axles Retracted)	16' 4" (4.87m)
Outside Turning Radius (Axles Extended)	21' (6.40m)
Raise / Lower Time	5 / 5.5 minutes
Tires (Foam-filled 24-ply)	445/50-710 (44.5cm x 118.9cm)
Controls	Proportional joystick
Drive System	4WD

POWER	
Power Source	115hp Kubota V3800 diesel engine

WEIGHT	
Weight	96,000 lbs (43,545kg)

WORKING ENVELOPE

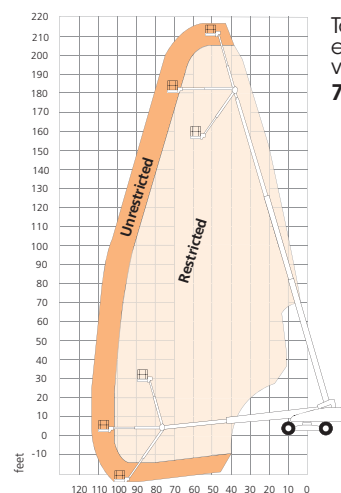

Total envelope volume:
7.11 million ft³

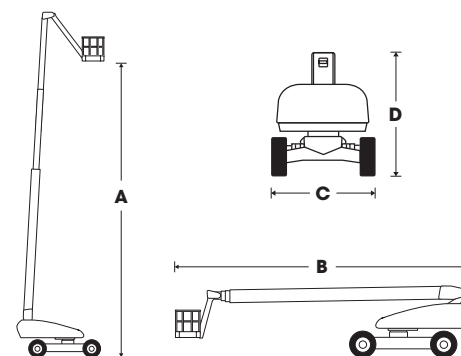

STANDARD FEATURES

- Snorkel Guard™ secondary guarding system
- Hydraulic platform rotation
- Secondary platform controls
- 360° continuous turntable rotation
- 5 steering modes—front axle, rear axle, crab, complementary and lateral
- 4-wheel drive
- All proportional controls
- Remote lower control panel
- Tri-entry platform with high-grip aluminum floor
- Power line to platform
- Drive motion alarm
- Dual lanyard attachment points
- Foam-filled tires
- Tool tray
- Flashing amber strobe
- 2-year parts & labor warranty
- 5-year structural warranty
- ANSI compliant

OPTIONS

- AC generator 110V/240V
- Airline to platform
- Cold weather package
- Extreme cold weather package
- Extreme environment package
- Environmental hydraulic oil
- Glazier package
- Light package
- Pipe rack
- Special paint colors

snorkel

www.snorkellifts.com

P.O. Box 1160
St. Joseph, MO 64502-1160, USA
Tel: 1 (785) 989-3000
Toll-Free: 1 (800) 255-0317
Email: sales.usa@snorkellifts.com