

EPV16A

TRUCK MOUNTED BOOM LIFT



- Working height of 15.8m
- Low cost truck mounted articulated boom lift
- Designed to be fitted to most 5500kg and greater GVM Vehicles
- Simple and easy to use and maintain
- Versatile, all-steel boom construction

 **snorkel**[™]
www.snorkellifts.com

TRUCK MOUNTED BOOM LIFT

EPV16A

DIMENSIONS

	EPV16A
Max. working height	15.8m
Max. platform height	13.8m
Horizontal outreach	7.1m
Platform length	0.61m
Platform width	1.07m
Overall width (A)*	1.95m
Overall length (B)*	6.75m
Stowed height (C)*	2.8m

PERFORMANCE

Platform capacity	200kg
Levelling	Mechanical
Chassis levelling	Auto
Turntable rotation	540° non-continuous

POWER

Power source	Petrol
Optional power source	Diesel, truck mounted PTO
Hydraulic system	Live hydraulic system

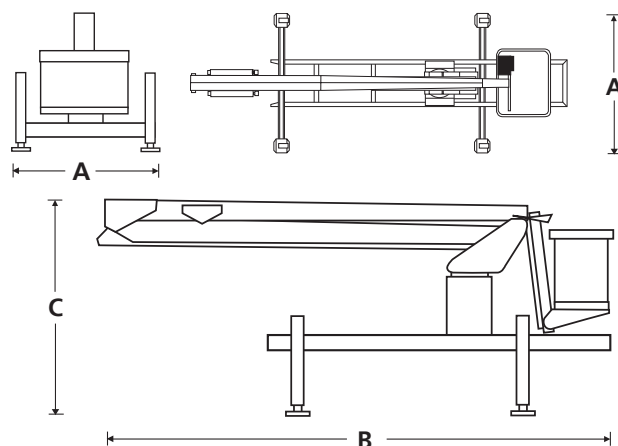

STANDARD FEATURES

- All steel boom and base construction
- Stabiliser/boom interlock
- Emergency bleed down
- Colour or number coded wiring
- Automatic self-levelling stabilizers
- Hour meter
- Full steel deck with perimeter handrails
- Fail safe hydraulics with check valves
- 10.9m height cutout switch
- 5 year structural warranty

OPTIONS

- AC outlet in platform
- Flashing light on boom
- LV insulation
- Safety harness and lanyard
- Hydraulic outlet in platform
- Airline to platform

WORKING ENVELOPE

